

**CHASSIS – PROF 6 ZR CC**

NO	MMA 01 054 110	REV	1	DATE	2020/09/02
----	----------------	-----	---	------	------------

# ELIET MANUAL

## PROF 6

MMA 01 054 110

CHASSIS - PROF 6 ZR CC

NUMBER	ARTICLE	DESCRIPTION	QUANTITY
1	BS 512 000 820	BOLT M8X20 DIN 933	12
2	BS 533 000 800	LOCK WASHER M8 DIN 127B	12
3	BS 531 000 800	WASHER M8 DIN 125	18
4	MPA 01 054 120	ANTI-RETURN	1
5	BR 000 212 040	GROMMETS 120/200/40	1
6	BS 512 000 620	BOLT M6X20 DIN 933	6
7	BS 531 000 600	WASHER M6 DIN 125	14
8	MPA 01 054 360	SUPPORT BATTERY	1
9	BS 502 000 600	SELF LOCKING NUT M6 DIN 985	6
10	BS 512 001 050	BOLT M10X100 DIN 933	1
11	BS 501 001 000	NUT M10 DIN 934	2
12	MPA 01 074 440	SPACER RING TENSION ENGINE	2
13	BS 511 000 842	BOLT M8X50 DIN 931	1
14	MPA 01 054 050	CHASSIS PROF 6 ZR CC	1
15	BS 512 001 045	BOLT M10X65 DIN 933	1
16	BS 501 000 600	NUT M6 DIN 934	2
17	MPA 01 054 210	COUNTRE PLATE SAFETY BAR	1
18	BS 511 000 630	BOLT M6X30 DIN 931	2
19	BS 501 901 600	SELF LOCKING NUT M16	1
20	BS 501 901 202	NUT M12X1 DIN 439B	1
21	BS 351 601 624	SPRING LOADED PLUNJER M16X24	1
22	BN 000 212 550	LOCKING BOLTS WITH LOCKING GROOVE	1
23	BS 512 000 812	BOLT M8X12 DIN 933	2
24	BS 534 000 800	LOCK WASHER M8 DIN 6798A	2
25	BR 600 130 301	ANTIVIBRATION BLOCKS 30X30B M8X16	2
26	BS 502 000 800	SELF LOCKING NUT M8 DIN 985	3
27	MPA 01 054 200	SAFETY BAR	1
28	MPA 01 054 230	FRONT FIXATION RUBBER PROTECTION	1
29	BR 902 000 010	RUBBER PROTECTION	1
30	MPA 01 054 220	BACK FIXATION RUBBER PROTECTION	1

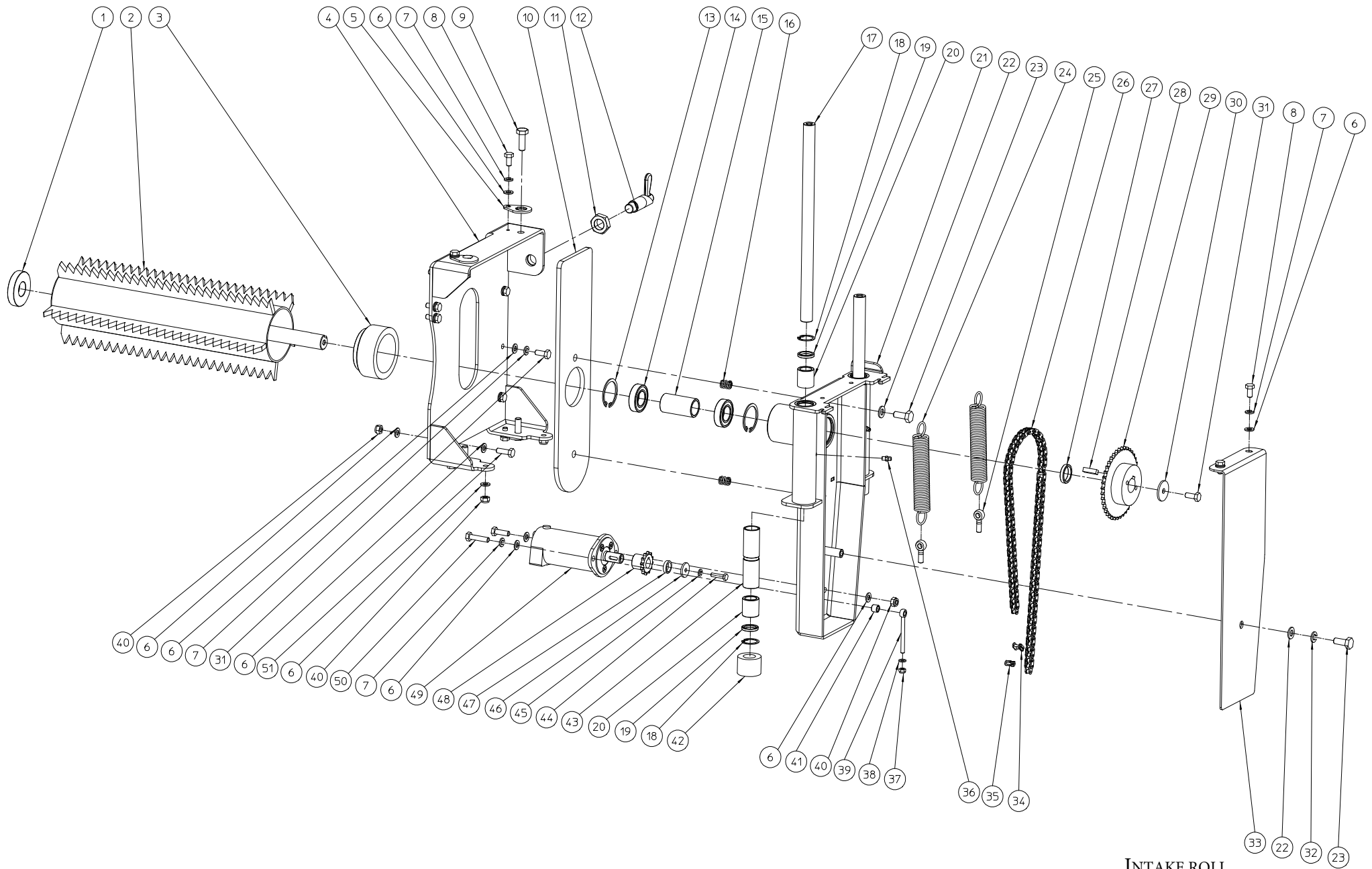

INTAKE ROLL

AMENEUR - PROF 6 ZR CC OR						
NO	MMA 01 054 120	REV	1	DATE	2020/09/02	

# ELIET MANUAL

## PROF 6

MMA 01 054 120

INTAKE ROLL - PROF 6 ZR CC OR

NUMBER	ARTICLE	DESCRIPTION	QUANTITY
1	BR 910 000 970	NYLON GUIDE INTAKE ROLL	1
2	MPA 01 054 060	INTAKE ROLL	1
3	BR 910 000 980	NYLON PROTECTION INTAKE ROLL	1
4	MPA 01 054 070	SUPPORT INTAKE ROLL	1
5	MPA 01 054 750	FIXATING PLATE - BOLT INTAKE ROLL	4
6	BS 531 000 800	WASHER M8 DIN 125	20
7	BS 533 000 800	LOCK WASHER M8 DIN 127B	14
8	BS 512 000 816	BOLT M8X16 DIN 933	6
9	BS 512 001 030	BOLT M10X30 DIN 933	4
10	BR 910 001 030	NYLON COVER PLATE	1
11	BS 501 902 000	SELF LOCKING NUT K20	1
12	BO 150 003 150	PULL LOCK WITH HANDLE 15MM	1
13	BB 002 000 470	RETAINING RING 32 DIN 472	2
14	BL 002 504 703	BEARING 6005 ZZ	2
15	MPA 01 470 430	SPACER	1
16	BV 911 000 010	SPRING 14X2X16	2
17	MPA 01 054 090	AXLE	2
18	BB 002 000 280	RETAINING RING 28 DIN 472	4
19	BR 302 120 284	SEAL 20X28X4	4
20	BL 866 010 010	BRONZE BUSH BEARING FMTC20	4
21	MPA 01 054 110	SUPPORT HYDR. ENGINE INTAKE ROLL	1
22	BS 531 001 000	WASHER M10 DIN 125	3
23	BS 512 001 025	BOLT M10X25 DIN 933	3
24	BV 919 000 010	SPRING	2
25	BS 551 000 830	EYE BOLT M8X30 DIN 444	2
26	BA 101 085 020	CHAINE	1
27	MPA 01 470 420	SPACER RING	1
28	BB 341 080 725	KEY 8X7X25 DIN 6880	1
29	BA 161 040 251	SPROCKET SIMPLEX 3/8"X7/32" 40T	1
30	BS 532 008 356	WASHER M8X35X3	1
31	BS 512 000 820	BOLT M8X20 DIN 933	8
32	BS 533 001 000	LOCK WASHER M10 DIN 127B	1
33	MPA 01 054 080	COVER PLATE INTAKE ROLL	1
34	BA 151 200 000	CONNECTING CHAIN LINK SIMPLEX 3/8"X7/32"	1
35	BA 151 400 000	CONNECTING CHAIN LINK SIMPLEX (1/2) 3/8"	1
36	BY 100 106 100	GREASE FITTING M6 DIN 71412	2
37	BS 502 000 600	SELF LOCKING NUT M6 DIN 985	1
38	BS 531 000 600	WASHER M6 DIN 125	1
39	BS 551 100 646	EYE BOLT M6X70 DIN 444	1
40	BS 502 000 800	SELF LOCKING NUT M8 DIN 985	4

<b>NUMBER</b>	<b>ARTICLE</b>	<b>DESCRIPTION</b>	<b>QUANTITY</b>
41	MPA 01 054 810	SPACER	1
42	BR 900 001 810	RUBBER SPACER	2
43	MPA 01 054 100	SPACER BAR	2
44	BS 512 000 625	BOLT M6X25 DIN 933	1
45	BS 533 000 600	LOCK WASHER M6 DIN 127B	1
46	BS 532 006 276	WASHER M6X27X3	1
47	MPA 01 054 910	SPACER HYDR. ENGINE	1
48	BA 161 012 162	SPROCKET SIMPLEX 3/8"X7/32" 12T	1
49	BH 331 205 000	HYDRAULIC ENGINE EPMM 50CC	1
50	BS 512 000 835	BOLT M8X35 DIN 933	1
51	BS 512 000 825	BOLT M8X25 DIN 933	2

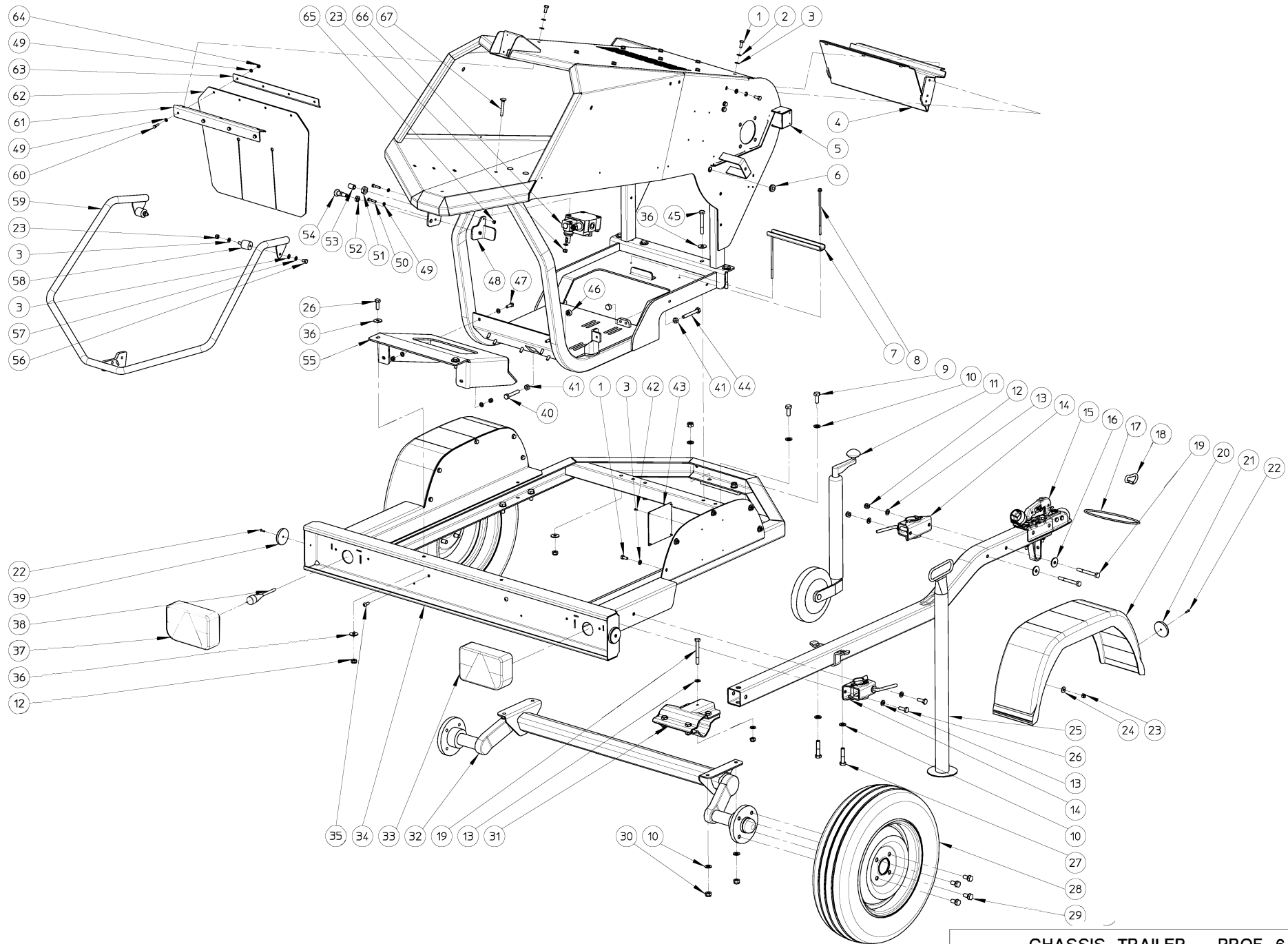

**CHASSIS TRAILER – PROF 6 OR**

NO	<b>MMA 01 054 130</b>	REV	1	DATE	2020/09/02
----	-----------------------	-----	---	------	------------

# ELIET MANUAL

PROF 6

MMA 01 054 130

CHASSIS TRAILER - PROF 6 OR

NUMBER	ARTICLE	DESCRIPTION	QUANTITY
1	BS 512 000 820	BOLT M8X20 DIN 933	22
2	BS 533 000 800	LOCK WASHER M8 DIN 127B	12
3	BS 531 000 800	WASHER M8 DIN 125	45
4	MPA 01 054 120	ANTI-RETURN	1
5	MPA 01 054 140	CHASSIS TRAILER	1
6	BR 000 212 040	GROMMETS 120/200/40	1
7	MPA 01 054 160	FIXATING PLATE BATTERY	1
8	BS 511 400 657	HEXAGON FLANGE BOLTS M6X170 DIN 6921	2
9	BS 512 001 230	BOLT M12X30 DIN 933	4
10	BS 531 001 200	WASHER M12 DIN 125	12
11	BY 727 000 100	SUPPORT WHEEL	1
12	BS 502 001 000	SELF LOCKING NUT M10 DIN 985	11
13	BS 531 001 000	WASHER M10 DIN 125	8
14	BY 728 010 100	CLAMP SUPPORT WHEEL	2
15	BY 709 601 004	TRAILER HANDLEBAR 1850MM	1
16	BS 532 010 356	WASHER M10X35X3	2
17	BY 709 601 200	SECURITY CABLE TRAILER	1
18	BY 522 080 080	HOOK 80X8MM	1
19	BS 511 001 049	BOLT M10X90 DIN 931	3
20	BY 722 400 400	MUDGUARD TRAILER	2
21	BY 708 112 010	ROUND REFLECTOR WHITE D60	2
22	BB 221 104 160	POP PLUG ALU 3.9X16 DIN 7337 A	4
23	BS 502 000 800	SELF LOCKING NUT M8 DIN 985	24
24	BS 532 008 223	WASHER M8X22X1.5	10
25	BY 709 600 602	TRAILER SUPPORT	1
26	BS 512 001 030	BOLT M10X30 DIN 933	4
27	BS 511 001 243	BOLT M12X55 DIN 931	2
28	BW 054 055 000	TRAILER TIRE	2
29	BS 512 301 220	BOLT M12X1.5X20 DIN 961	8
30	BS 502 001 200	SELF LOCKING NUT M12 DIN 985	6
31	BY 709 601 100	FIXATION TRAILER HANDLEBAR	1
32	BY 726 020 080	TIRE SUPPORT	1
33	BY 707 120 502	LIGHT - RIGHT SIDE	1
34	MPA 01 074 030	CHASSIS TRAILER	1
35	BS 522 500 820	SCREW M8X20 ISO 7380	2
36	BS 532 010 305	WASHER M10X30X2.5	12
37	BY 707 120 501	LIGHT - LEFT SIDE	1
38	BY 707 120 503	CONNECTING CABLE	1
39	BY 708 122 010	REFLECTOR	2
40	BS 512 001 045	BOLT M10X65 DIN 933	1

NUMBER	ARTICLE	DESCRIPTION	QUANTITY
41	BS 501 001 000	NUT M10 DIN 934	2
42	BB 221 103 100	POP PLUG ALU 3X10 DIN 7337 A	4
43	MPA 01 052 680	IDENTIFICATION PLATE TRAILER	1
44	BS 512 001 048	BOLT M10X80 DIN 933	1
45	BS 511 001 048	BOLT M10X80 DIN 931	4
46	MPA 01 074 440	SPACER RING TENSION ENGINE	2
47	BS 512 000 825	BOLT M8X25 DIN 933	7
48	MPA 01 054 210	COUNTRE PLATE SAFETY BAR	1
49	BS 531 000 600	WASHER M6 DIN 125	10
50	BS 511 000 630	BOLT M6X30 DIN 931	2
51	BS 501 901 600	SELF LOCKING NUT M16	1
52	BS 501 901 202	NUT M12X1 DIN 439B	1
53	BS 351 601 624	SPRING LOADED PLUNJER M16X24	1
54	BN 000 212 550	LOCKING BOLTS WITH LOCKING GROOVE	1
55	MPA 01 054 150	CONNECTING PLATE CABLE	1
56	BS 512 000 812	BOLT M8X12 DIN 933	2
57	BS 534 000 800	LOCK WASHER M8 DIN 6798A	2
58	BR 600 130 301	ANTIVIBRATION BLOCKS 30X30B M8X16	2
59	MPA 01 054 200	SAFETY BAR	1
60	BS 512 000 620	BOLT M6X20 DIN 933	4
61	MPA 01 054 230	FRONT FIXATION RUBBER PROTECTION	1
62	BR 902 000 010	RUBBER PROTECTION	1
63	MPA 01 054 220	BACK FIXATION RUBBER PROTECTION	1
64	BS 502 000 600	SELF LOCKING NUT M6 DIN 985	4
65	BS 501 000 600	NUT M6 DIN 934	2
66	BH 400 401 101	DISTRIBUTION BLOCK	1
67	BS 554 100 844	BOLT M8X60 DIN603	3



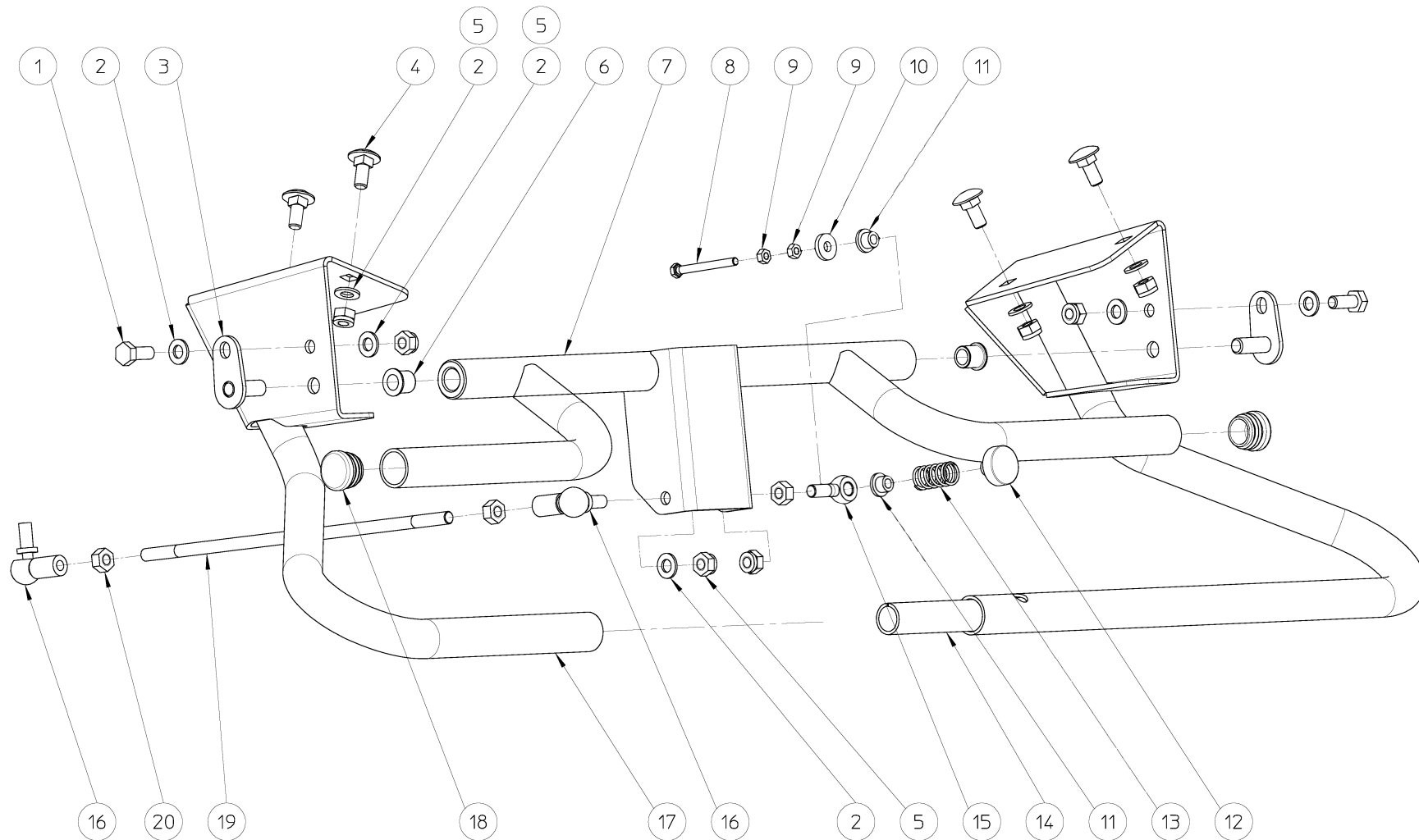

**COMMAND INTAKE ROLL – PROF 6 ZR CC**

NO	<b>MMA 01 054 140</b>	REV	1	DATE	2020/09/02
----	-----------------------	-----	---	------	------------

# ELIET MANUAL

## PROF 6

MMA 01 054 140

COMMAND INTAKE ROLL - PROF 6 ZR CC

NUMBER	ARTICLE	DESCRIPTION	QUANTITY
1	BS 512 000 820	BOLT M8X20 DIN 933	2
2	BS 531 000 800	WASHER M8 DIN 125	9
3	MPA 01 440 600	FIXATION PART	2
4	BS 554 100 820	BOLT M8X20 DIN 603	4
5	BS 502 000 800	SELF LOCKING NUT M8 DIN 985	8
6	BR 112 101 490	NYLON BUSHING WITH COLLAR (10/14/17.5x1	2
7	MPA 01 054 170	COMMAND INTAKE ROLL	1
8	BS 512 000 542	BOLT M5	1
9	BS 501 000 500	NUT M5 DIN 934	2
10	BS 531 200 600	WASHER M6 DIN 7349	1
11	BR 112 060 800	NYLON BUSHING WITH COLLAR (6/10/15x8.5/2	2
12	BE 120 040 070	MAGNET MAESTRO	1
13	BV 911 000 050	COMPRESSION SPRING 1.5 X 15 X 28	1
14	MPA 01 054 180	TRACTION SUPPORT BAR	1
15	BS 551 000 830	EYE BOLT M8X30 DIN 444	1
16	BA 230 010 800	BALL JOINT M8	2
17	MPA 01 054 190	TRACTION SUPPORT BAR	1
18	BR 020 501 250	TUBE CAP Ø 25MM	2
19	MPA 01 054 870	COMMAND DISTRIBUTION BLOCK	1
20	BS 501 000 800	NUT M8 DIN 934	3

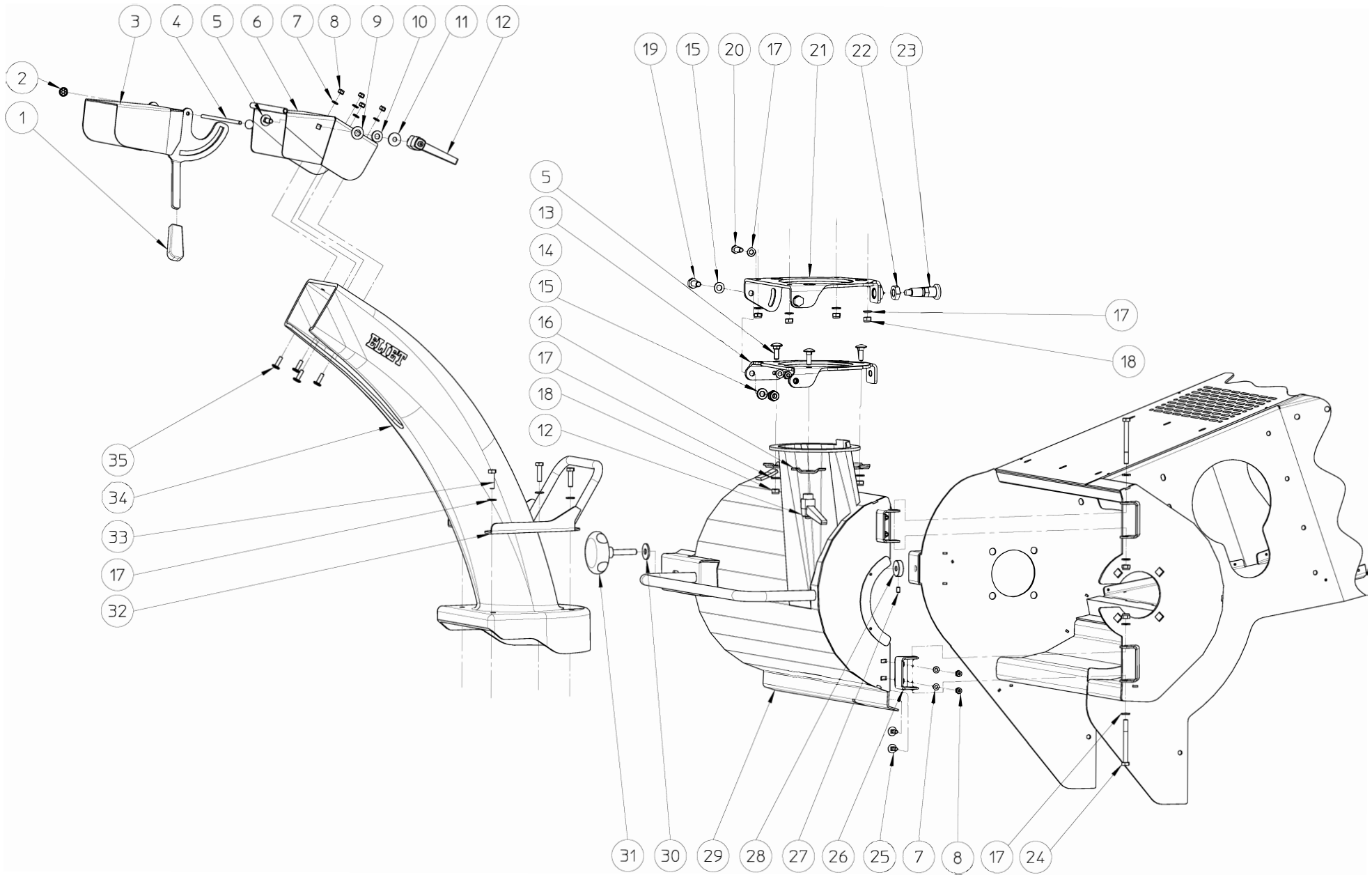

**BACK COVER -PROF 6 ZR CC OR**

NO	MMA 01 054 160	REV	1	DATE	2020/07/14
----	----------------	-----	---	------	------------

# ELIET MANUAL

PROF 6

MMA 01 054 160

BACK COVER - PROF 6 ZR CC

NUMBER	ARTICLE	DESCRIPTION	QUANTITY
1	BN 230 100 202	PLASTIC HANDGRIPP 15x5x6 PVC	1
2	BB 011 000 060	STARLOCK 6MM	2
3	MPA 01 054 260	DISCHARGE DIRECTOR	1
4	MPA 01 052 670	TUBE FOR DISCHARGE DIRECTOR	1
5	BS 554 100 825	BOLT M8X25 DIN 603	4
6	MPA 01 054 290	SUPPORT DISCHARGE DIRECTOR	1
7	BS 531 000 600	WASHER M6 DIN 125	8
8	BS 502 000 600	SELF LOCKING NUT M6 DIN 985	8
9	BR 111 120 100	NYLON BUSHING (12.2X24X1.3)	1
10	BR 111 100 200	NYLON BUSHING (10.5/21x2.5)	1
11	BS 532 008 253	WASHER M8X25X1.5	1
12	BN 530 108 800	CLAMP LEVERS	2
13	MPA 01 054 280	ROTATION RING DISCHARGE CHUTE	1
14	BS 502 001 000	SELF LOCKING NUT M10 DIN 985	2
15	BS 531 001 000	WASHER M10 DIN 125	4
16	MPA 01 073 520	TUBE CONNECTION	3
17	BS 531 000 800	WASHER M8 DIN 125	16
18	BS 502 000 800	SELF LOCKING NUT M8 DIN 985	9
19	BS 512 001 025	BOLT M10X25 DIN 933	2
20	BS 512 000 825	BOLT M8X25 DIN 933	1
21	MPA 01 054 270	SUPPORT ROTATION RING	1
22	BS 501 901 601	NUT M16	1
23	BN 000 216 580	SELF LOCKING NUT WITH SPRING	1
24	BS 511 000 848	BOLT M8X80 DIN 931	2
25	BS 554 100 620	BOLT M6X20 DIN 603	4
26	MPA 01 054 980	HINGE BACK COVER	2
27	BS 023 000 610	SET SCREW M6X10 DIN 916	1
28	MPA 01 054 890	NUT BACK COVER	1
29	MPA 01 054 250	BACK COVER	1
30	BS 532 010 305	WASHER M10X30X2.5	1
31	BN 630 410 420	LOB KNOW M10	1
32	MPA 01 073 280	HANDLE EJECTION	1
33	BS 512 000 830	BOLT M8X30 DIN 933	4
34	BR 930 070 010	DISCHARGE TUNNEL	1
35	BS 552 100 620	SCREW M12X40 TYPE KF	4

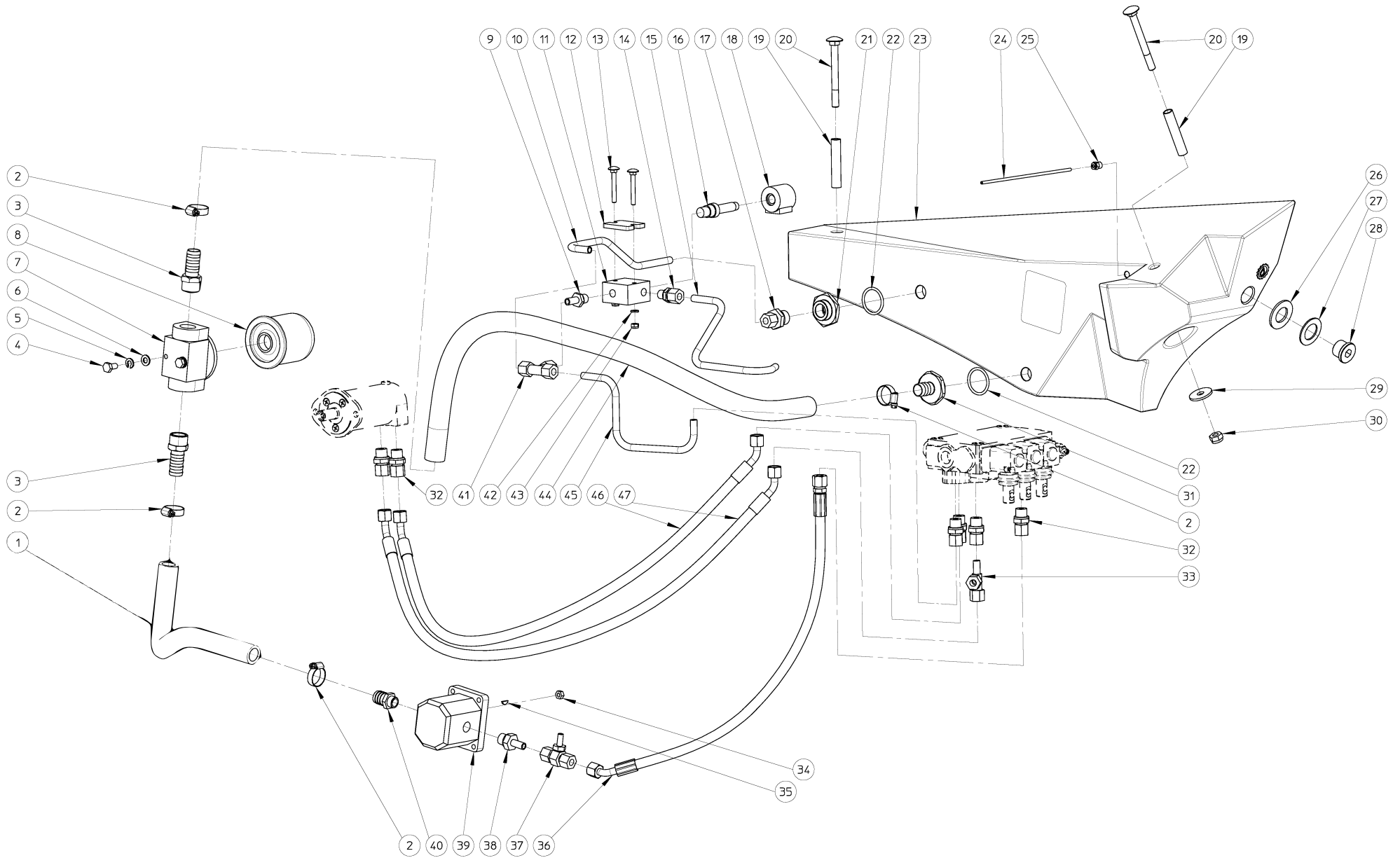

**HYDRAULICS – PROF 6 ZR CC OR**

NO	<b>MMA 01 054 170</b>	REV	2	DATE
----	-----------------------	-----	---	------

# ELIET MANUAL

PROF 6

MMA 01 054 170

HYDRAULICS - PROF 6 ZR

NUMBER	ARTICLE	DESCRIPTION	QUANTITY
1	BR 212 019 085	FLEXIBLE HYDRAULICS TUBE 19MM	1
2	BT 670 117 290	HOSE CLAMP 17X29MM	4
3	BT 136 261 219	ADAPTOR Ø 19MM - 3/4"	2
4	BS 512 000 816	BOLT M8X16 DIN 933	2
5	BS 533 000 800	LOCK WASHER M8 DIN 127B	2
6	BS 531 000 800	WASHER M8 DIN 125	2
7	BH 280 612 120	SUPPORT HYDRAULIC FILTER 3/4"	1
8	BH 280 212 010	FIXATION HYDRAULIC FILTER	1
9	BH 512 611 004	STANDPIPE ADAPTOR 10Lx1/4"	1
10	MPA 01 054 720	RETURN TUBE	1
11	BH 410 001 610	ELECTROVANNE	1
12	MPA 01 054 540	SUPPORT ELECTROVANNE	1
13	BS 554 100 642	BOLT M6X50 DIN 603	2
14	BH 509 211 004	MALE STUD COUPLING 10Lx1/4"	1
15	MPA 01 054 710	ELECTROVANNE TUBE	1
16	BH 410 001 620	VALVE ELECTROVANNE	1
16	BH 410 001 621	DADO FISSAGGIO VALVOLA ELETTR.	1
17	BH 509 211 008	MALE STUD COUPLING 10Lx1/2"	1
18	BH 410 001 630	COIL ELECTROVANNE	1
19	MPA 01 054 530	TUBE SUPPORT TANK	2
20	BS 554 101 050	BOLT M10	2
21	MPA 01 311 360	CONNECTOR	1
22	BH 812 345 350	O-RING 34,52 X 3,53 MM VITON	2
23	BY 717 212 010	HYDR. TANK 10L	1
24	BH 646 020 040	TUYAU D'HUILE	1
25	BH 642 020 040	COUPLING	1
26	RDVD 01 054 017	CAP SEAL	1
27	MPA 01 054 970	WASHER	1
28	BH 518 501 200	COUPLING	1
29	BS 532 010 356	WASHER M10X35X3	2
30	BS 502 001 000	SELF LOCKING NUT M10 DIN 985	2
31	MPA 01 073 890	ADAPTOR Ø 20MM - 1/2"	1
32	BH 509 211 006	MALE STUD COUPLING 10Lx3/8"	6
33	BH 512 111 000	ROTARY L-FITTING FEMALE 10L	1
34	BS 501 000 700	NUT M7 DIN 934	1
35	BH 281 201 011	GEAR WHEEL Z14 25X22 DIN5482 GR 2/1	1
36	BB 321 020 512	KEY 2X5X12.65 DIN 6888	1
37	BH 551 040 630	TUBE	1
38	BH 563 000 100	MANOMETER COUPLER 10LxM16x2	1
39	BH 210 103 200	HYDRAULIC PUMP 3.2CC	1
40	BH 512 671 006	STANDPIPE ADAPTOR 10SR3/8"	1

<b>NUMBER</b>	<b>ARTICLE</b>	<b>DESCRIPTION</b>	<b>QUANTITY</b>
41	BT 136 260 620	CONNECTION	1
42	BH 510 011 000	EQUAL TEE 10L	1
43	BS 531 000 600	WASHER M6 DIN 125	2
44	BS 502 000 600	SELF LOCKING NUT M6 DIN 985	2
45	BR 212 019 038	NYLON NUT M6	1
46	MPA 01 054 700	RETURN HYDR. OIL	1
47	BH 551 040 870	FLEXIBLE HYDRAULIC HOSE 1/4"x870	1
48	BH 551 040 890	FLEXIBLE HYDRAULIC HOSE 1/4"x895	1

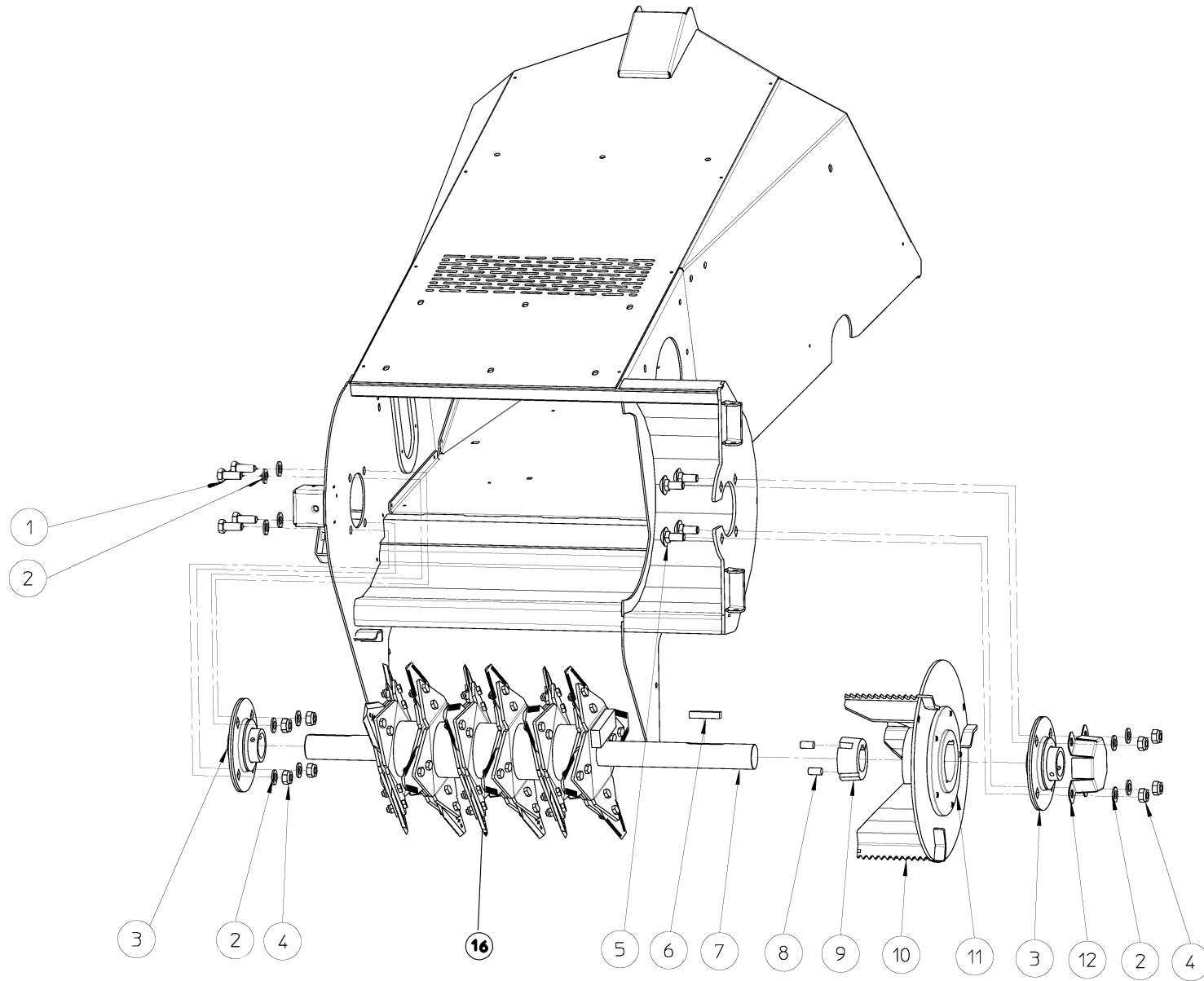

**ROTOR + IMPELLER - PROF 6 ZR CC OR**

NO	<b>MMA 01 054 180</b>	REV	1	DATE	2020/09/02
----	-----------------------	-----	---	------	------------



# ELIET MANUAL

## PROF 6

MMA 01 054 180

ROTOR + IMPELLER - PROF 6

NUMBER	ARTICLE	DESCRIPTION	QUANTITY
1	BS 512 001 230	BOLT M12X30 DIN 933	4
2	BS 531 001 200	WASHER M12 DIN 125	12
3	BL 801 604 001	KIT BEARING UCPF 208 COMPLETE	2
4	BS 502 001 200	SELF LOCKING NUT M12 DIN 985	8
5	BS 554 101 230	BOLT M12	4
6	BB 341 121 050	KEY DIN 6880	1
7	MPA 01 054 310	ROTOR ASS'Y	1
8	BB 501 311 220	SET SCREW 7/16"X7/8"	2
9	BB 501 154 000	TAPER LOCK TL 2012-40	1
10	MPA 01 470 190	IMPELLER	1
11	BA 281 753 201	FLANGE Ø175x32 - TL 2012	1
12	MPA 01 054 580	PROTECTION BEARING	1
16	BU 401 300 202	SET LAME	1
16	BS 011 300 827	VITE M8 LAME PROF6 SPRPROF	1
16	BS 502 000 811	DADO M8 LAME PROF6 SPRPROF	1

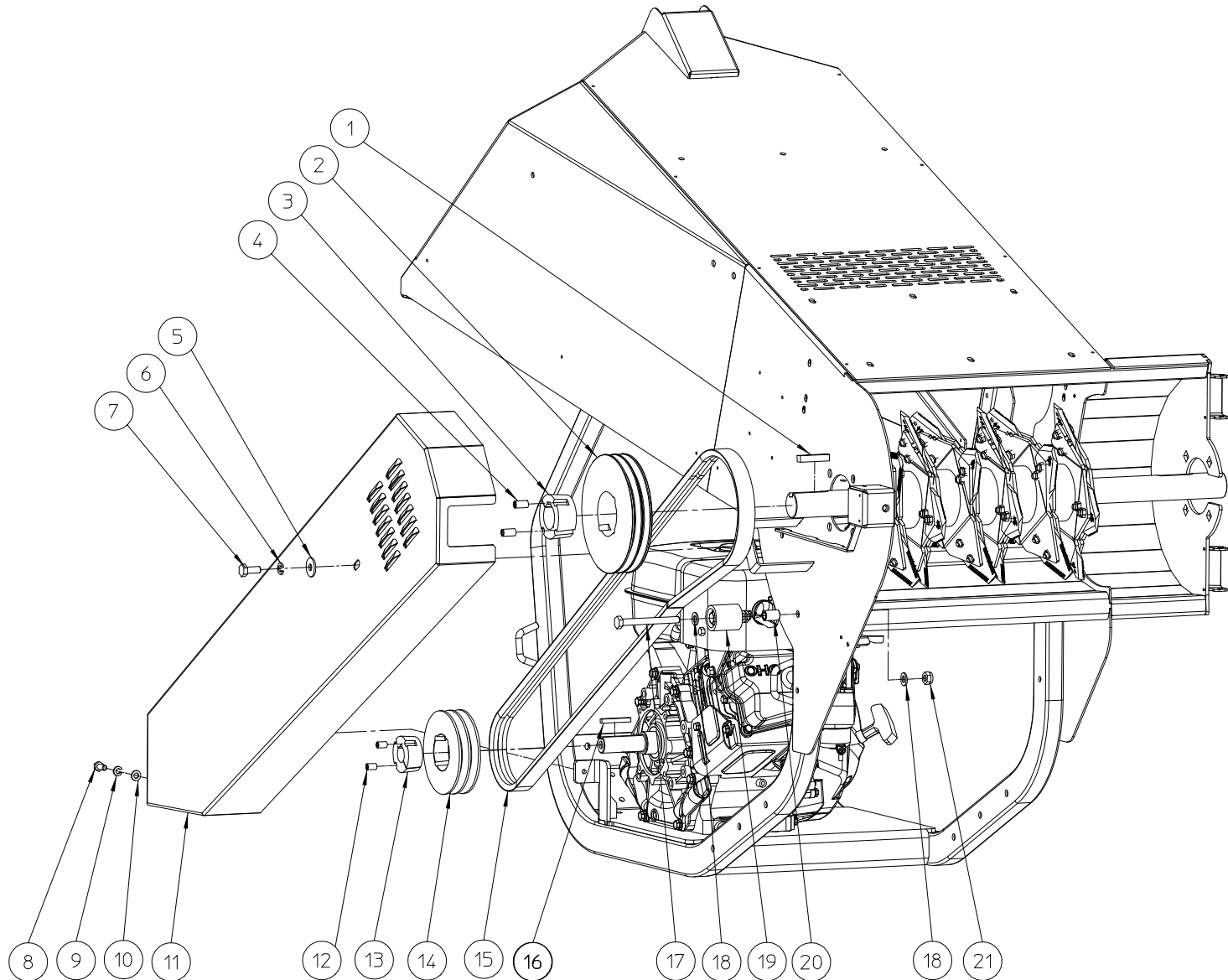

TRANSMISSION – PROF6 ZR CC OR				
NO	MMA 01 054 190	REV	1	DATE 2020/07/09

# ELIET MANUAL

## PROF 6

MMA 01 054 190

TRANSMISSION - PROF 6 ZR CC OR

NUMBER	ARTICLE	DESCRIPTION	QUANTITY
1	BB 341 121 050	KEY DIN 6880	1
2	BA 562 701 801	PULLEY SPA 180	1
3	BB 501 154 000	TAPER LOCK TL 2012-40	1
4	BB 501 311 220	SET SCREW 7/16"X7/8"	2
5	BS 532 010 305	WASHER M10X30X2.5	1
6	BS 533 001 000	LOCK WASHER M10 DIN 127B	1
7	BS 512 001 025	BOLT M10X25 DIN 933	1
8	BS 512 000 820	BOLT M8X20 DIN 933	1
9	BS 533 000 800	LOCK WASHER M8 DIN 127B	1
10	BS 531 000 800	WASHER M8 DIN 125	1
11	MPA 01 054 320	PROTECTIVE BELTCOVER	1
12	BB 501 310 160	SET SCREW 3/8"X5/8"	2
13	BB 501 231 600	TAPER LOCK TL 1610-1"	1
14	BA 562 701 251	PULLEY SPA 125	1
15	BA 552 222 400	BELT XPA 2240	1
16	BB 342 060 650	KEY 6.35X6.35X50 DIN 6880	1
17	BS 512 001 050	BOLT M10X100 DIN 933	1
18	BS 531 001 000	WASHER M10 DIN 125	2
19	BA 599 006 200	BELT GUIDER	1
20	MPA 01 054 820	SPACER	1
21	BS 502 001 000	SELF LOCKING NUT M10 DIN 985	1

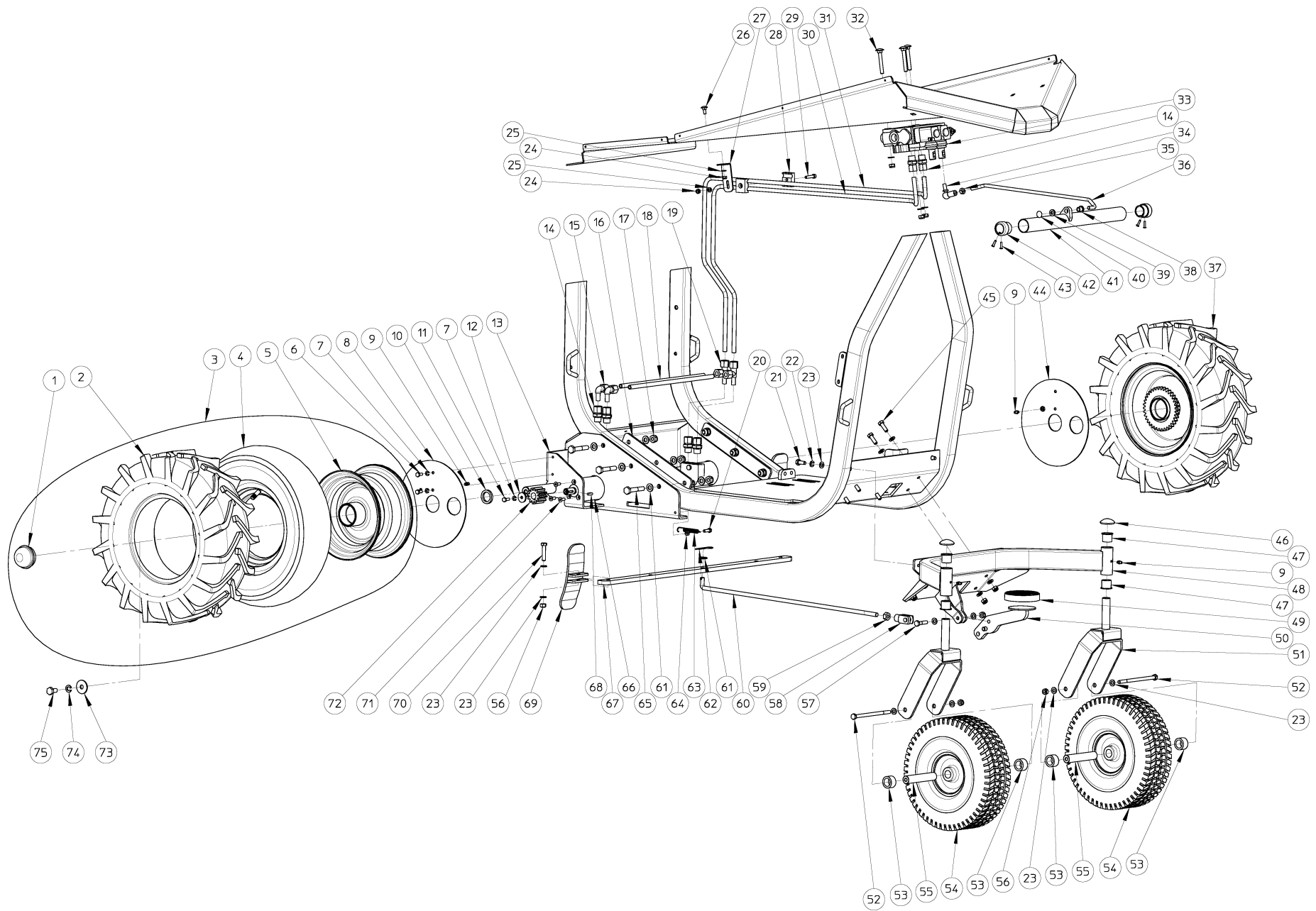

**CHASSIS LOWER SIDE - PROF 6 ZR**

NO	MMA 01 054 200	REV	1	DATE	2020/07/09
----	----------------	-----	---	------	------------

# ELIET MANUAL

## PROF 6

MMA 01 054 200

CHASSIS LOWER SIDE - PROF 6 ZR

NUMBER	ARTICLE	DESCRIPTION	QUANTITY
1	BY 728 035 520	WHEEL CAP	0
2	BW 910 430 020	RUBBER TIRE	0
3	BW 041 025 021	KIT COMPLETE TIRE	1
4	BW 910 430 030	INSIDE TIRE	0
5	BW 708 025 070	DIABOLO	0
6	BS 512 000 614	BOLT M6X14 DIN 933	4
7	BS 533 000 600	LOCK WASHER M6 DIN 127B	6
8	MPA 01 054 340	PROTECTION TIRE	1
9	BY 100 106 100	GREASE FITTING M6 DIN 71412	4
10	MPA 01 054 570	WASHER	2
11	BS 512 000 616	BOLT M6X16 DIN 933	2
12	BS 532 006 276	WASHER M6X27X3	2
13	MPA 01 054 370	SUPPORT PLATE TIRE	1
14	BH 509 211 006	MALE STUD COUPLING 10Lx3/8"	6
15	BH 511 911 000	ANGULAR ROTARY FITTING 10L	2
16	MPA 01 054 500	REINFORCEMENT PLATE	2
17	BS 502 001 000	SELF LOCKING NUT M10 DIN 985	6
18	MPA 01 054 440	HYDRAULIC TUBES	2
19	BH 512 111 000	ROTARY L-FITTING FEMALE 10L	2
20	BS 512 000 620	BOLT M6X20 DIN 933	2
21	BS 512 000 820	BOLT M8X20 DIN 933	2
22	BS 533 000 800	LOCK WASHER M8 DIN 127B	2
23	BS 531 000 800	WASHER M8 DIN 125	25
24	BS 502 000 600	SELF LOCKING NUT M6 DIN 985	2
25	BS 531 000 600	WASHER M6 DIN 125	2
26	BS 554 100 616	BOLT M6X16 DIN 603	1
27	MPA 01 051 325	SUPPORT FIXATION	1
28	BH 711 020 110	PIPE CLAMP RBPR-110	1
29	BS 521 100 630	SCREW M6X30 DIN 912	1
30	MPA 01 054 430	HYDRAULIC PIPE	1
31	MPA 01 054 420	HYDRAULIC PIPE	1
32	BS 554 100 844	BOLT M8X60 DIN603	3
33	BH 400 401 201	DISTRIBUTION BLOCK	1
34	BA 230 010 800	BALL JOINT M8	1
35	BS 501 000 800	NUT M8 DIN 934	1
36	MPA 01 054 510	CONTROL ROD DISTR. BLOCK	1
37	BW 041 025 020	RIGHT TIRE	1
38	BR 112 081 300	NYLON BUSHING WITH COLLAR (8/11/16x13/2	1
39	BR 111 080 300	NYLON BUSHING (8,2/16X3)	1
40	BB 011 000 080	STARLOCK 8MM	1

NUMBER	ARTICLE	DESCRIPTION	QUANTITY
41	MPA 01 073 430	COMMAND TUBE	1
42	BR 910 000 010	NYLON BUSHING WITH COLLAR (25/30/34x30/	2
43	BB 221 104 160	POP PLUG ALU 3.9X16 DIN 7337 A	4
44	MPA 01 054 330	PROTECTION TIRE	1
45	BS 512 000 825	BOLT M8X25 DIN 933	5
46	BB 011 000 200	STARLOCK 20MM	2
47	BR 112 202 100	NYLON BUSHING WITH COLLAR (20/24/29x21/	4
48	MPA 01 054 380	SUPPORT FRONT TIRES	1
49	BR 900 000 110	RUBBER SOCKS DIA 90X18MM	1
50	MPA 01 054 350	BRAKE	1
51	MPA 01 054 410	FIXATION PART FRONT TIRES	2
52	BS 511 000 854	BOLT M8X140 DIN 931	2
53	MPA 01 340 380	SPACER WHEELSHAFT	4
54	BW 029 020 001	WHEEL 4.00-4 PROF 5	2
55	MPA 01 051 175	WHEEL SHAFT CASTER WHEEL	2
56	BS 502 000 800	SELF LOCKING NUT M8 DIN 985	13
57	BS 511 000 835	BOLT M8X35 DIN 931	1
58	BS 556 001 000	FORK M10X20 DIN 71752	1
59	BS 501 001 000	NUT M10 DIN 934	1
60	MPA 01 054 390	BRAKE TUBE	1
61	BS 531 001 000	WASHER M10 DIN 125	13
62	BB 040 102 040	HAIRPIN COTTER 2MM DIN 11024	1
63	BV 912 000 030	SPRING	2
64	BS 501 000 600	NUT M6 DIN 934	2
65	BS 511 001 044	BOLT M10X60 DIN 931	6
66	BH 331 203 210	HYDRAULIC ENGINE EPMM 32CC	2
67	MPA 01 054 400	BRAKE TUBE	1
68	BB 351 050 516	KEY 5X5X16 DIN 6885A	2
69	MPA 01 070 410	FOOT BRAKE	2
70	BS 512 000 840	BOLT M8X40 DIN 933	2
71	BS 522 100 616	SCREW M6X16 DIN 7991	6
72	BA 603 001 201	GEAR M3 12T	2
73	BS 532 010 355	WASHER M10X35X2.5	2
74	BS 533 001 000	LOCK WASHER M10 DIN 127B	2
75	BS 512 001 020	BOLT M10X20 DIN 933	2

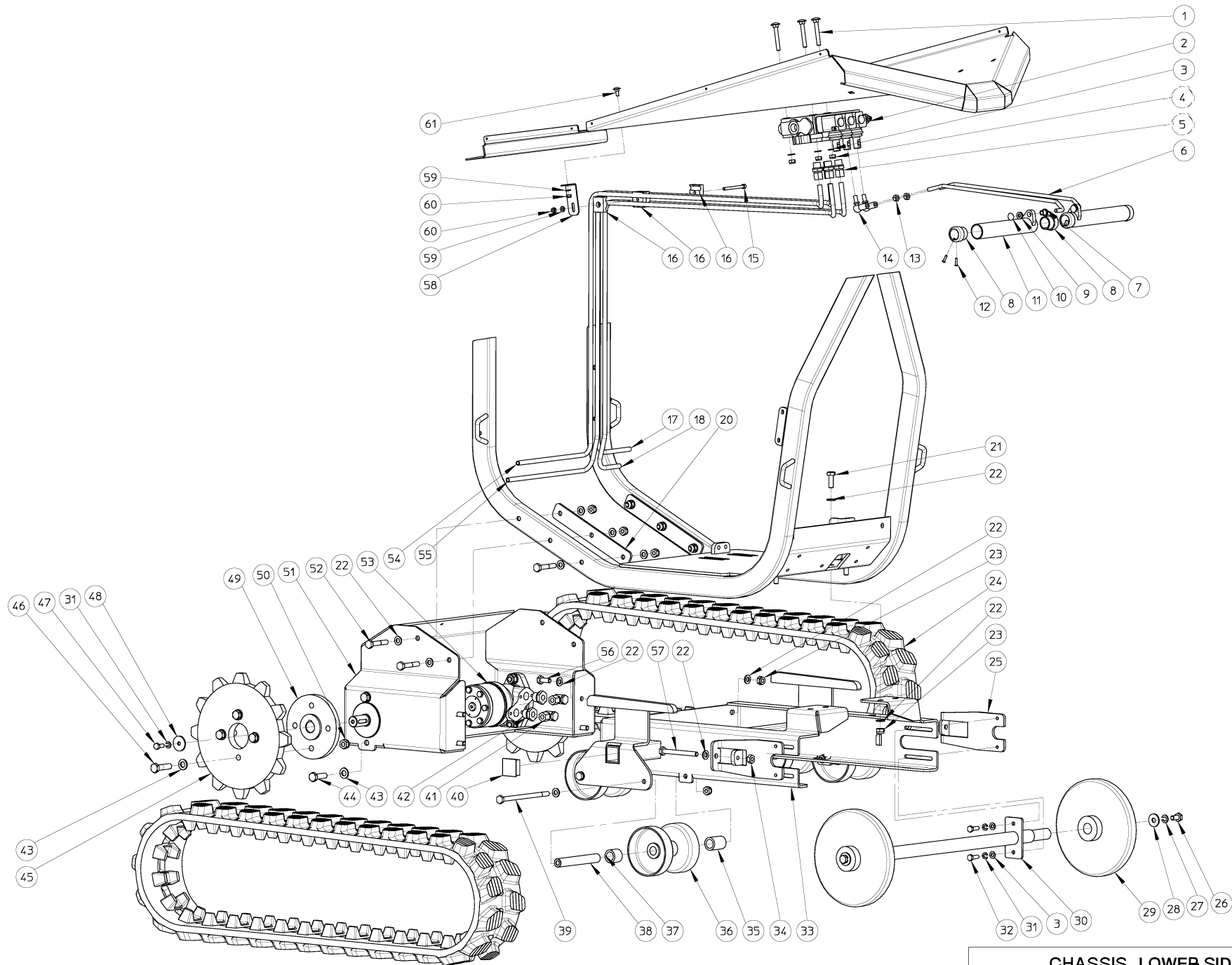

**CHASSIS LOWER SIDE PROF 6 CC**

NO	MMA 01 054 210	REV	1	DATE	2020/07/09
----	----------------	-----	---	------	------------

# ELIET MANUAL

## PROF 6

MMA 01 054 210

CHASSIS LOWER SIDE - PROF 6 CC

NUMBER	ARTICLE	DESCRIPTION	QUANTITY
1	BS 554 100 844	BOLT M8X60 DIN603	3
2	BH 400 401 301	DISTRIBUTION BLOCK	1
3	BS 531 000 800	WASHER M8 DIN 125	7
4	BS 502 000 800	SELF LOCKING NUT M8 DIN 985	3
5	BH 509 211 006	MALE STUD COUPLING 10Lx3/8"	4
6	MPA 01 054 510	CONTROL ROD DISTR. BLOCK	2
7	BR 112 081 300	NYLON BUSHING WITH COLLAR (8/11/16x13/2	2
8	BR 910 000 010	NYLON BUSHING WITH COLLAR (25/30/34x30/	4
9	BR 111 080 300	NYLON BUSHING (8,2/16X3)	2
10	BB 011 000 080	STARLOCK 8MM	2
11	MPA 01 073 440	CONTROL PIPE CROSS COUNTRY	2
12	BB 221 104 160	POP PLUG ALU 3.9X16 DIN 7337 A	8
13	BS 501 000 800	NUT M8 DIN 934	2
14	BA 230 010 800	BALL JOINT M8	2
15	BS 521 100 646	SCREW M6X70 DIN 912	1
16	BH 711 020 100	PIPE CLAMP B-10MM	2
17	MPA 01 054 660	HYDRAULIC TUBE	1
18	MPA 01 054 670	HYDRAULIC TUBE	1
20	MPA 01 054 500	REINFORCEMENT PLATE	2
21	BS 512 001 030	BOLT M10X30 DIN 933	4
22	BS 531 001 000	WASHER M10 DIN 125	34
23	BS 502 001 000	SELF LOCKING NUT M10 DIN 985	18
24	BW 815 072 340	RUBBER TRACK	2
25	MPA 01 054 470	SUPPORT TIGHTNER RUBBER TRACK	2
26	BS 512 001 020	BOLT M10X20 DIN 933	2
27	BS 533 001 000	LOCK WASHER M10 DIN 127B	2
28	BS 532 010 305	WASHER M10X30X2.5	2
29	BW 622 725 002	WHEEL	2
30	MPA 01 054 450	SUPPORT WHEELS	1
31	BS 533 000 800	LOCK WASHER M8 DIN 127B	6
32	BS 512 000 825	BOLT M8X25 DIN 933	4
33	MPA 01 054 490	SUPPORT	1
34	BS 501 001 000	NUT M10 DIN 934	2
35	MPA 01 054 640	INSIDE SPACER	4
36	BW 611 520 002	DIABOLO	4
37	MPA 01 054 630	OUTSIDE SPACER	4
38	MPA 01 054 620	DIABOLO TUBE	4
39	BS 511 001 057	BOLT M10	4
40	BR 021 140 400	CAP 40X40	2
41	BH 513 111 004	BANJO 10Lx1/4"	4



NUMBER	ARTICLE	DESCRIPTION	QUANTITY
42	BH 514 100 804	REDUCTION STUD (M-F) 1/2"-1/4"	4
43	BS 531 001 200	WASHER M12 DIN 125	16
44	BS 512 001 240	BOLT M12X40 DIN 933	4
45	MPA 01 054 460	SPROCKET	2
46	BS 511 001 242	BOLT M12X50 DIN 931	8
47	BS 512 000 820	BOLT M8X20 DIN 933	2
48	BS 532 008 356	WASHER M8X35X3	2
49	BA 281 504 502	HUB REAR WHEEL Ø12,5MM	2
50	BS 502 001 200	SELF LOCKING NUT M12 DIN 985	12
51	MPA 01 054 480	SUPPORT HYDR. ENGINE	1
52	BS 511 001 044	BOLT M10X60 DIN 931	6
53	BH 331 525 000	HYDRAULIC ENGINE MR N 250 CD	2
54	MPA 01 054 680	HYDRAULIC TUBE	1
55	MPA 01 054 690	HYDRAULIC TUBE	1
56	BS 512 001 025	BOLT M10X25 DIN 933	4
57	BS 512 001 050	BOLT M10X100 DIN 933	2
58	MPA 01 051 325	SUPPORT FIXATION	1
59	BS 531 000 600	WASHER M6 DIN 125	2
60	BS 502 000 600	SELF LOCKING NUT M6 DIN 985	2
61	BS 554 100 616	BOLT M6X16 DIN 603	1

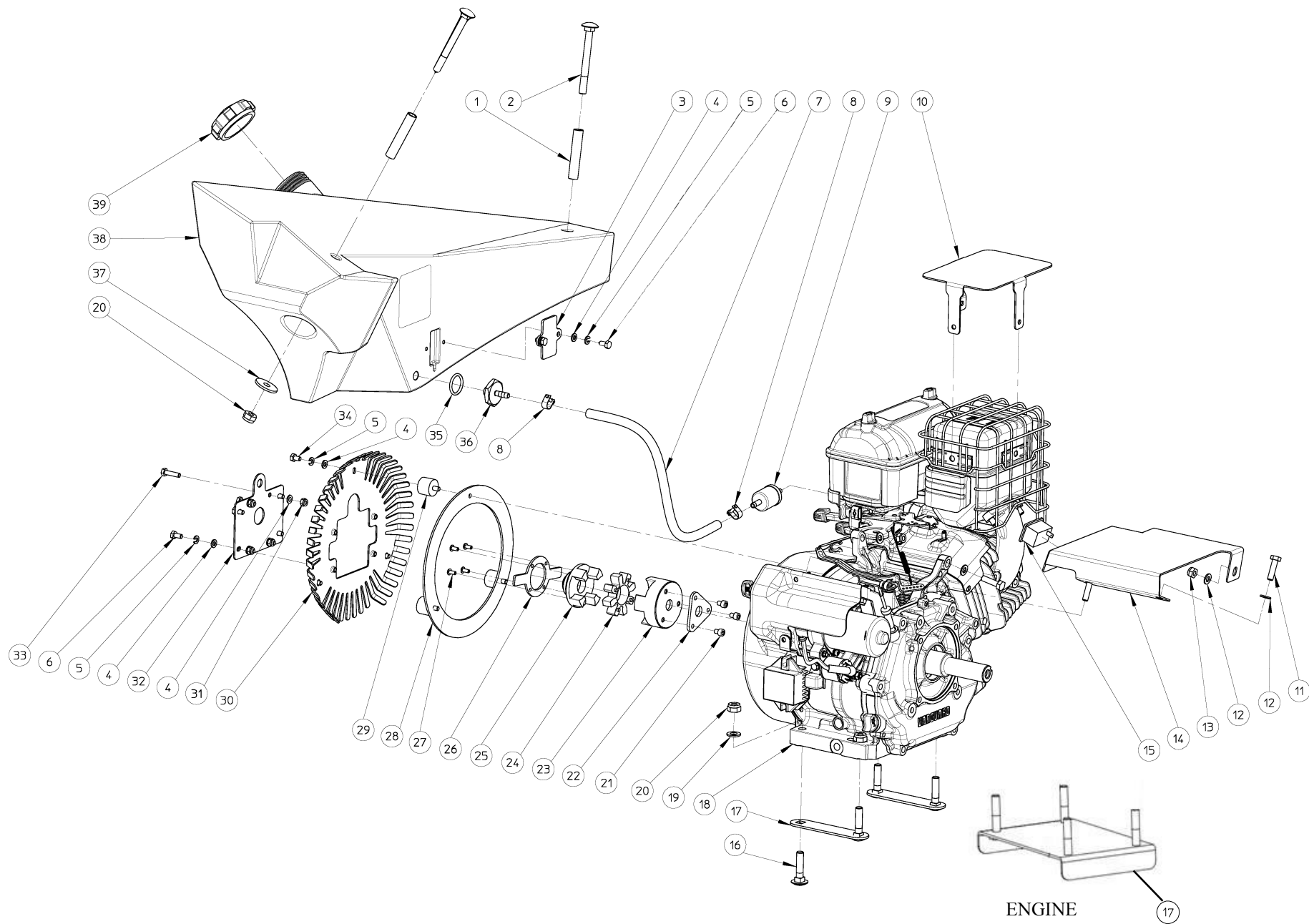

ENGINE

MOTEUR VANGUARD – PROF 6 ZR CC OR

NO	MMA 01 054 240	REV	2	DATE	2020/07/13
----	----------------	-----	---	------	------------

# ELIET MANUAL

PROF 6

MMA 01 054 240

ENGINE VANGUARD - PROF 6 ZR CC OR

NUMERO	ARTICLE	DESCRIPTION	QUANTITÉ
1	MPA 01 054 530	SPACER	2
2	BS 554 101 050	BOLT M10	2
3	BR 910 001 040	SUPPORT	1
4	BS 531 000 600	WASHER M6 DIN 125	13
5	BS 533 000 600	LOCK WASHER M6 DIN 127B	9
6	BS 512 000 612	BOLT M6X12 DIN 933	6
7	BR 202 007 045	FUEL TUBE	1
8	BT 670 111 130	HOSE CLAMP 11X13MM	2
9	BM 260 493 629	FUEL FILTER	1
10	MPA 01 054 930	PROTECTION EXHAUST	1
11	BS 512 000 830	BOLT M8X30 DIN 933	4
12	BS 531 000 800	WASHER M8 DIN 125	8
13	BS 502 000 800	SELF LOCKING NUT M8 DIN 985	4
14	MPA 01 054 900	ENGINE PLATE	1
15	BE 412 430 000	MAINTENANCE METER	1
16	BS 554 101 041	BOLT M10X45 DIN603	4
17	MPA 01 054 880	ENGINE SUPPORT PLATES	2
17	MPA 01 055 290	ENGINE SUPPORT PLATES FROM 2022	1
18	BM 201 314 002	ENGINE 14HP	1
19	BS 531 001 000	WASHER M10 DIN 125	4
20	BS 502 001 000	SELF LOCKING NUT M10 DIN 985	6
21	BS 521 100 608	BOLT UMBRACO M6	3
22	MPA 01 054 990	CENTRE PIECE	1
23	MPA 01 055 120	ELASTIC COUPLING (ENGINE SIDE)	1
24	BA 201 240 000	ELASTIC COUPLING RUBBER FLECTOR	1
25	BA 201 220 101	ELASTIC COUPLING ALU FLANGE (PUMP SIDE)	1
26	MPA 01 073 720	ROTAION MEASURING POINT	1
27	BB 221 005 100	POP PLUG STEEL 4.8X10 DIN 7337 A	4
28	MPA 01 054 610	VENTILATOR REINFORCEMENT	1
29	BR 600 225 201	ANTIVIBRATION BLOCKS 25X20B M6X10	3
30	MPA 01 054 600	ENGINE PUMP SUPPORT	1
31	BS 502 000 600	SELF LOCKING NUT M6 DIN 985	4
32	MPA 01 054 780	SUPPORT PUMP SENSOR	1
33	BS 512 000 625	BOLT M6X25 DIN 933	4
34	BS 512 000 610	BOLT M6X10 DIN 933	3
35	BH 812 249 350	O-RING Ø 24,99 X 3,53 MM VITON	1
36	MPA 01 311 210	TAILPIECE	1
37	BS 532 010 356	WASHER M10X35X3	2
38	BY 717 212 011	FUEL TANK 11L	1
39	BH 720 505 585	CAP FOR TANK	1
49	BS 511 041 125	BOLT UNF	1

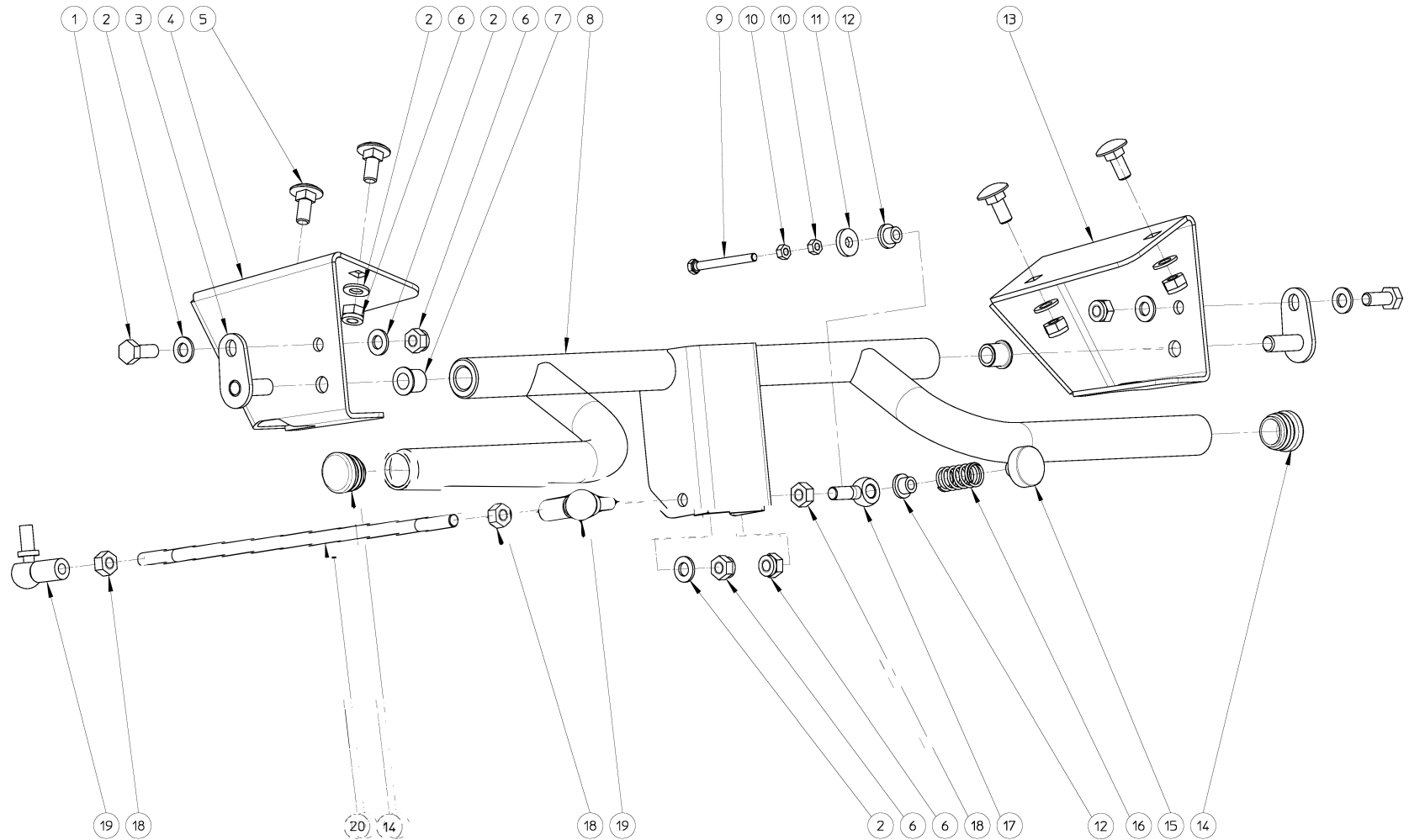

**COMMAND INTAKE ROLL – PROF 6 OR**

NO	<b>MMA 01 054 260</b>	REV	1	DATE	2020/09/02
----	-----------------------	-----	---	------	------------

# ELIET MANUAL

## PROF 6

MMA 01 054 260

COMMAND INTAKE ROLL - PROF 6 OR

NUMBER	ARTICLE	DESCRIPTION	QUANTITY
1	BS 512 000 820	BOLT M8X20 DIN 933	2
2	BS 531 000 800	WASHER M8 DIN 125	9
3	MPA 01 440 600	FIXATION PART	2
4	MPA 01 054 960	SUPPORT TRACTION LEFT SIDE	1
5	BS 554 100 820	BOLT M8X20 DIN 603	4
6	BS 502 000 800	SELF LOCKING NUT M8 DIN 985	8
7	BR 112 101 490	NYLON BUSHING WITH COLLAR (10/14/17.5x1	2
8	MPA 01 054 170	COMMAND INTAKE ROLL	1
9	BS 512 000 542	BOLT M5	1
10	BS 501 000 500	NUT M5 DIN 934	2
11	BS 531 200 600	WASHER M6 DIN 7349	1
12	BR 112 060 800	NYLON BUSHING WITH COLLAR (6/10/15x8.5/2	2
13	MPA 01 054 950	SUPPORT TRACTION RIGHT SIDE	1
14	BR 020 501 250	TUBE CAP Ø 25MM	2
15	BE 120 040 070	MAGNET MAESTRO	1
16	BV 911 000 050	COMPRESSION SPRING 1.5 X 15 X 28	1
17	BS 551 000 830	EYE BOLT M8X30 DIN 444	1
18	BS 501 000 800	NUT M8 DIN 934	3
19	BA 230 010 800	BALL JOINT M8	2
20	MPA 01 054 870	COMMAND DISTRIBUTION BLOCK	1

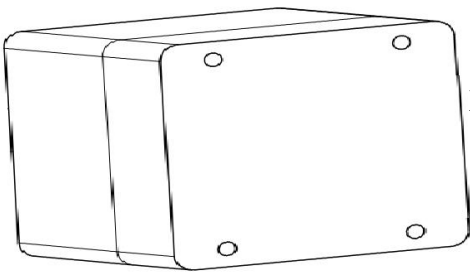

BE141511072 SCATOLA CENTRALINA PROF6

BE 120 030 020 SENSORE  
CAMERA TRITURAZIONE

BE 099 005 402 CABLAGGIO SENSORE  
CAMERA DI TRITURAZIONE

BE 400 010 600 SENSORE E  
CABLAGGIO  
SERBATOIO CARBURANTE

IFM CAPTEUR  
KQ 5100

BE400010203 CABLAGGIO SENSORE GIRI

BE400010500 SENSORE GIRI MOTORE

TACHOMETER RPM

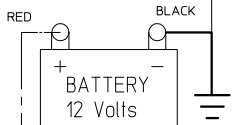
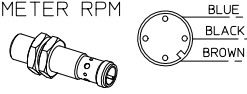

BE 240 120 300  
BATTERIA

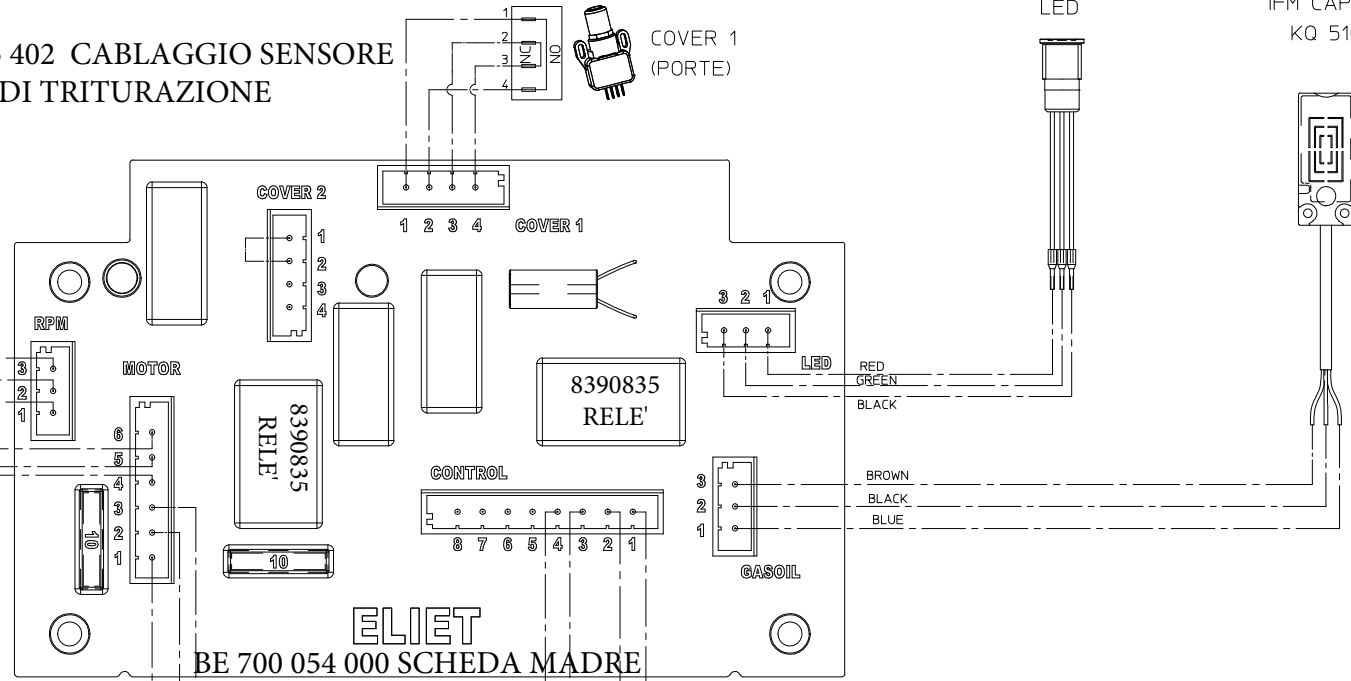

ELIET  
BE 700 054 000 SCHEDA MADRE

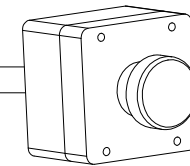

BE 122 650 003  
EMERGENCY  
BUTTON

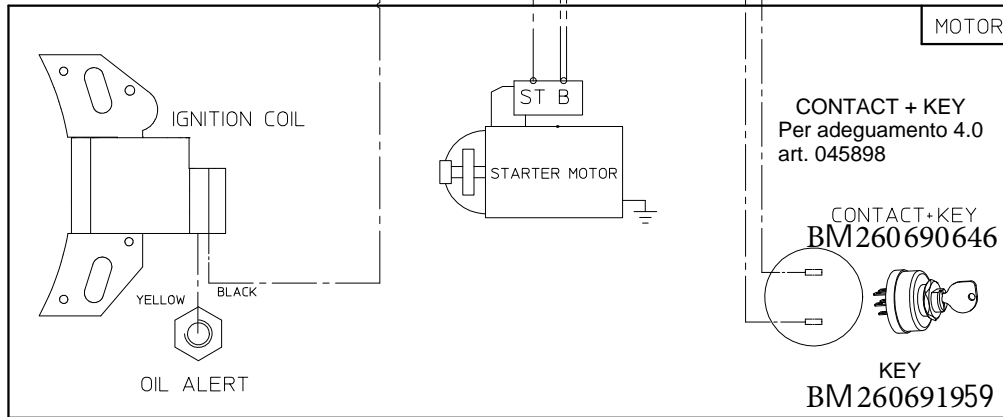

CONTACT + KEY  
Per adeguamento 4.0  
art. 045898

CONTACT+KEY  
BM260690646

KEY  
BM260691959

BH 410 001 410 ATTUATORE  
E CABLAGGIO ELETTROVALVOLA

B&S EDITION

PROF 6 - ELECTRICAL DIAGRAM				
NO	BE 900 054 010	REV	1	DATE 2020/06/02

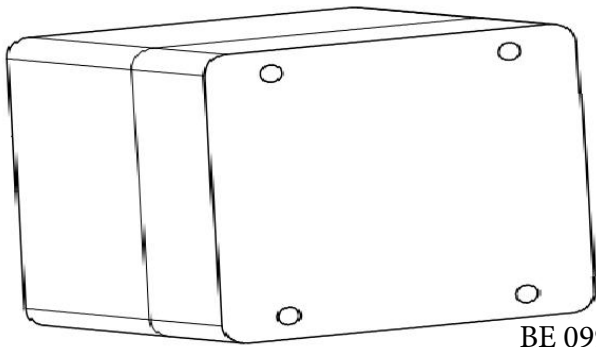

BE141511072 SCATOLA CENTRALINA PROF6

BE 120 030 020 SENSORE  
CAMERA TRITURAZIONE

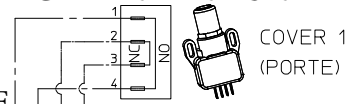

BE 099 005 402 CABLAGGIO SENSORE  
CAMERA DI TRITURAZIONE

BE400010203 CABLAGGIO SENSORE GIRI

BE400010500 SENSORE GIRI MOTORE  
TACHOMETER RPM

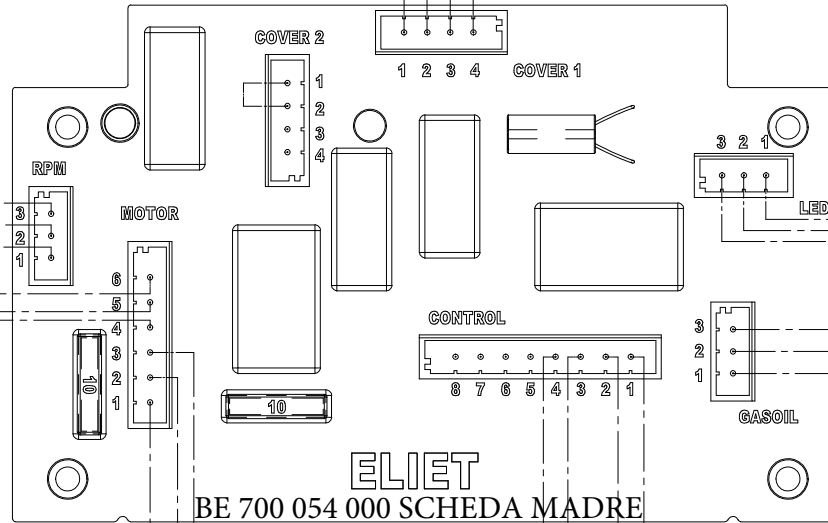
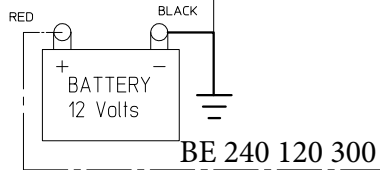
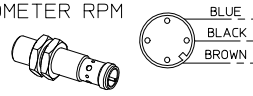

ELIET

BE 700 054 000 SCHEDA MADRE

LED

IFM CAPTEUR  
KQ 5100

RED  
GREEN  
BLACK

BROWN  
BLACK  
BLUE

GASOIL

BE 122 650 003

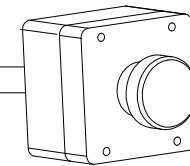

EMERGENCY  
BUTTON

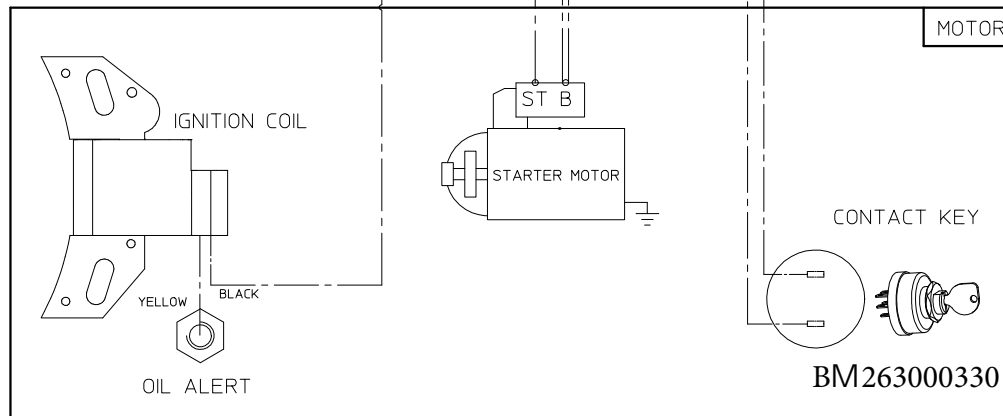

BH 410 001 410 ATTUATORE  
E CABLAGGIO ELETTROVALVOLA

BROWN  
BLUE

SUBARU EDITION

PROF 6 - ELECTRICAL DIAGRAM				
NO	BE 900 054 010	REV	1	DATE 2020/06/02